

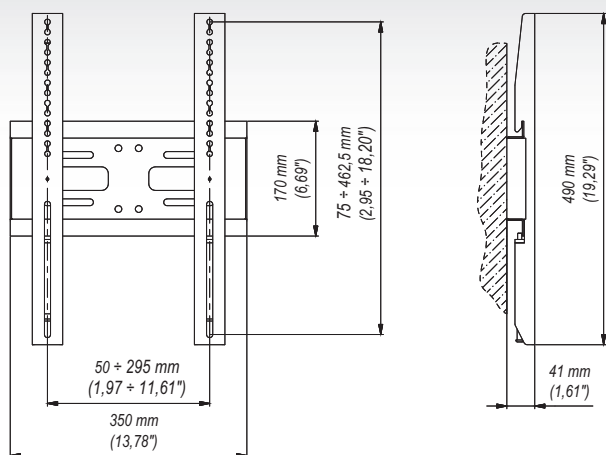

Features

- 1 **QUICK INSTALLATION**
easy installation of the product
- 2 **VERTICAL SCREEN INSTALLATION**
- 3 **SAFETY**
safety bolt



Technical Data



75x75 mm
100x100 mm
200x100 mm
200x200 mm
400x200 mm



60 Kg



26"-40"



41 mm



min. 50x75 mm
max. 295x462,5 mm

Trade Information

Index	Colour	Package	EAN
LWB3c-B	■	■	5908252961566
LWB3s-B	■	■	5908252961573

Package Dimensions [mm] (H x W x D)	540x300x45
Weight [Kg]	2,6

Accessories

Series TR



Series CM



SAP3



STD01

